



Welcome

TO MY

PRESENTATION

BY

Ass.Prof. Dr. Mohamed Akf



TOPIC

CAPSULES



Activate Windows
Go to Settings to activate Windows.

Content

- ❑ 1. Introduction
- ❑ Gelatin
- ❑ Hard Gelatin Capsule (HGC)
- ❑ Soft Gelatin Capsule (SGC)
- ❑ Difference between HGC & SGC
- ❑ Capsule shell
- ❑ Evaluation of capsules

HISTORY

- **In 1730**, the Pharmacist **De PAULI** from **Vienna** developed **oval shaped capsules** for covering up the unpleasant taste of the pure turpentine used for the treatment of gout
- **In 1834**, the Pharmacist **JOSEPH DUPLANC** from **FRONCOIS MOTHES** were granted Patent which covered a method for the producing , **single piece , olive shaped , gelatin capsules** which were closed after filling by a **drop of concentrated warm gelatin solution**
- **In 1846**, the Frenchman **JULES LEHUBY** first to suggest **Tow- Piece Capsule** produced by **dipping silver coated metal pins into a gelatin solution** and then drying them quickly
- **In 1931**, the author **COLTON** Designed a machine to manufacture **bodies and caps** and fitted them to form **hard gelatin capsule**.



CAPSULES



❑ Derived from Latin word called Capsula, meaning a small box

Definition: capsules are **solid dosage forms** in which the drug substance is enclosed within either a hard or soft soluble shell, usually formed from gelatin.

- The medication may be a **powder**, a **liquid** or a **semisolid mass**.
- Capsules are usually intended to be **administered orally** by swallowing them whole. Occasionally, capsules may be administered **rectally** or **vaginally**.



Advantages

- 1 **Provide a smooth, slippery, easily swallowed** by almost any adult with drink of water
- 2 They have an elegant and characteristic shapes and colours. The name of drug, strength and manufacturer can be imprinted on their surfaces to make them readily identified → **patient compliance** امتثال .
- 3 Enclosing the medication within capsule shells provides a **tasteless, odourless means of administering medication.**
- 3 The ready solubility **of gelatin at gastric pH provides rapid release** of medication in the stomach (uncompressed form of API).
- 4 They provide ready availability of the contained drug, since minimal excipient and little pressure are required to compact the material as is necessary in tableting.
- 5 Ideal for controlled release formulation in particular pellets.

Advantages (Cont.):

6. Since hard gelatin capsules may be compounded by the pharmacist, this dosage form offers physician's greater flexibility in dosages and drug combinations than is available with prefabricated medication according to patient requirement.
7. Capsules can be used to provide an enteric-coated or prolonged-release dosage form by coating with different polymers and waxes.
8. Require **fewer excipients**.
9. They can be filled **quickly and conveniently**.
10. Packaged and shipped by manufacturers at lower cost less breakage than liquid forms.
11. **Reduce stability problems** with sensitive drugs.

Capsules (Cont.):

Disadvantages:

1. Capsules are not suitable containers for liquids that dissolve gelatin, such as aqueous or hydroalcoholic solutions.
2. Very soluble salts, such as bromides or iodides should not be dispensed in capsules, as the rapid release of such materials may cause gastric irritation.
3. More prone to adherence to esophagus
4. Sensitive to temperature and humidity during storage →
(moisture shell content 12-16 %)
→ If less than 10%brittle and fragile
→ If more than 16%soft and sticky.
5. No possibility of fractioning dosage form.
6. Not suitable for efflorescent powder →soft and sticky.

Capsules (Cont.):

Disadvantages:

7. Not suitable for **deliquescent** (Calcium chloride)→
.....**brittle and fragile.**

Notes:

- *Deliquescent materials* which have strong affinity for moisture and will absorb relatively large amount of water from the atmosphere forming liquid solution
- *Efflorescent materials* which loss water of crystallization from a hydrate to atmosphere →.....**soft and sticky**

RAW MATERIALS



Activate Windows
Go to Settings to activate Windows.

Raw Materials



- Capsule shells are usually made from of mixture of **certain type of gelatin and water**
- The major pharmacopoeia; (European, Japanese & US) permit the use of gelatin or HPMC in order to produce a shell with low moisture content (about 12%).

They may also contain

1. Coloring agent (Mostly synthetic): such as azo dyes and xanthene dyes
2. Opacifying agent : Titanium oxide (white and make the capsule opaque to provide protection against light)
3. Sugar: up to 5%
4. H₂O- 12 -16 % (may vary depending on the storage condition)

Raw Materials



7. SO₂ (15%)- prevent decomposition during manufacture
8. Hardening agent.....Sucrose
9. Preservatives: as an in-process aid in order to prevent microbial growth during manufacture, as parabens
10. Wetting agents: sodium lauryl sulphate
 - Not more than 1 % w/w of **sod. Lauryl sulphate** is used in hard gelatin capsules to ensure that the lubricated metal molds are uniformly covered when dipped into gelatin solution and as wetting agent
11. Disintegrants: to break the powder or granule mass following release into the stomach

Raw Materials



7. Diluents: Diluents: to increase the bulk of the required weight fill. e.g.: lactose, mannitol, sorbitol, starch, etc
8. Lubricants and Glidants : talc, Mg stearate & Ca stearate
11. lactose, mannitol, sorbitol, starch, etc
12. Lubricants and Glidants : to reduce the interaction of the powders with the metal components of the capsule filling machine and to aid the powder flow
e.g.: talc, magnesium stearate & calcium stearate

Capsules (Cont.):



Raw materials:

1- Gelatin:

- Gelatin is heterogeneous ***solid protein*** product that is extracted from animal collagen derived from animal skin or bones by either partial acid extraction or partial alkaline hydrolysis.
- The sources of gelatins including animal bones, hide portions and frozen pork skin
 - Collagen ***properties varies according to the parent collagen source***, method of extraction, pH value, thermal degradation technique and electrolyte content
 - In commerce, it is available in the form of a fine powder, a coarse powder, flakes, or sheets.

Capsules (Cont.):



Raw materials:

1- Gelatin:

-It is the major component of the capsule. The reason for this is that gelatin possesses five basic properties:

A- Non-toxic.

B- Soluble in biological fluids at body temperature.

C- It is a good film-forming material → producing strong flexible film.

D- Solutions of high concentration, 40% w/v, are mobile at 50°C.

E- A solution in water changes from a **sol to a gel** at relatively low temperature only a few degrees above ambient محیط ب (Others require volatile solvents or large quantities of heat).

Raw materials: 1- Gelatin Types (Cont.):

It's prepared by *partial hydrolysis of collagen*, which is the main protein constituent of connective tissue, skin and bone.

Type A:

- Gelatin of skin (*Clear and flexible*)
- produced by acid hydrolysis of animal (pork) skins
- iso electric point at pH-9.
- Process of isolation take about 7to10 days

Type B:

- Gelatin of bone (*hard, nonclear and brittle*)
- produced by basic hydrolysis of bovine بقرى bones
- iso electric point at pH-4.7.
- Process of isolation take about 10 times longer than acid hydrolysis.

Factors affecting properties of gelatin

The most important properties of gelatin to capsule manufacturers:

1. Bloom value;

- Is a measurement of the gelling power and the strength of the resulting gel.
- Reflecting the average molecular weight of its constituents
- Gelatin generally falls between 50 and 300 bloom strength.

2. Gelling power;

- The key function of gelatin.
- The gelling power varies depending on the grade of gelatin
- Its measured in terms of bloom value.
- The higher the bloom value, the greater the ability to form gel & the stronger the gel strength.

Factors affecting properties of gelatin

3. Viscosity; (play role in capsule shell wall thickness)

- In general the higher the bloom, the greater the viscosity.
- Beef bone grades tend to have higher viscosity.
- Viscosity is determined by measuring the flow time of a 6.67% solution of gelatin through a U-tube viscometer at 60 °C.
- **preferred viscosity** range lies between 200 and 350 mP.

4. Foamability;

- In general pigskin grades tend to have better foaming properties.
- Gelatin lowers the surface tension, allowing for the incorporation of air, and stabilizes the foam once aerated
- Gelatin will also prevent crystal formation of sugars in the foam and maintain smoothness in texture

Factors affecting properties of gelatin

5. Melting point;

- Lower melting point gelatins dissolve faster in the mouth, therefore releasing the flavors more quickly for an instant taste sensation.
- Lower bloom grades tend to have lower melting points.

6. Color and odor;

- The gelatin should be as clear as possible in solution. →Clarity is measured using a turbidimeter
- The gelatin should be without odor.

7. pH;

- pH is measured using a pH meter on a 1% solution.
- It typical for gelatin solution lie between 4.5-6.5

CAPSULES

**HARD
GELATIN
CAPSULES
(TWO PIECE)**



**SOFT
GELATIN
CAPSULES
(ONE PIECE)**



PresenterMedia

Activate Windows
Go to Settings to activate Windows.

Types of capsules

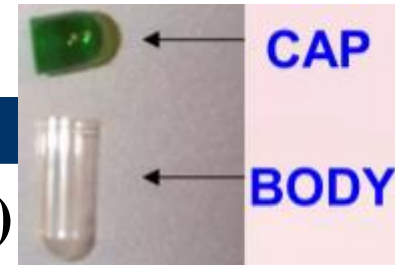

I. Hard gelatin (dry-filled) capsules (Two pieces)

- Consists of two pieces in the form of cylinders closed at one end
 - The shorter and wider pieceCap
 - The longer and narrower pieceBody
 - Cap fits over the open end of the longer piece (body)
 - The drug substance placed in the body and the caps are slid over it, hence enclosing the drug substance

II. Soft gelatine capsules (One piece)

- Consist of one piece and the medicaments are enclosed within gelatine shell



1- Hard gelatin capsules (Cont.):

Capsule sizes:

- HGCs tended for human uses are available in size ranged from No. 5 to No. 000
- No. 5 is the smallest one
- No. 000 is the largest one
- The capacity of capsules mainly depend on the **bulk density (D_b)** of the drug
- Lower D_b (light), \rightarrow the higher V_b , \rightarrow Bigger capsule size
- The standard shape of capsules is traditional, symmetrical bullet **رصاصية** shape

SIZE	VOLUME (cm ³)
000	1.37
00	0.95
0	0.68
1	0.50
2	0.37
3	0.30
4	0.21
5	0.13

1- Hard gelatin capsules (Cont.):

Selection of capsule size:

- The following specific formulation can be used

$$\text{formulation volume} = \frac{\text{Weight of formulation (dose) in gm}}{\text{Bulk density of formulation } \left(\frac{\text{gm}}{\text{ml}}\right)}$$

→ If the weight of formulation is 350 mg and its bulk density

0.75 g/ml

- What is the best size of capsule could be used?

Answer

$$V = 0.35 / 0.75 = 0.467 \text{ ml}$$

Capsule No. 1 is the best choice

1- Hard gelatin capsules (Cont.):

Capsule sizes:

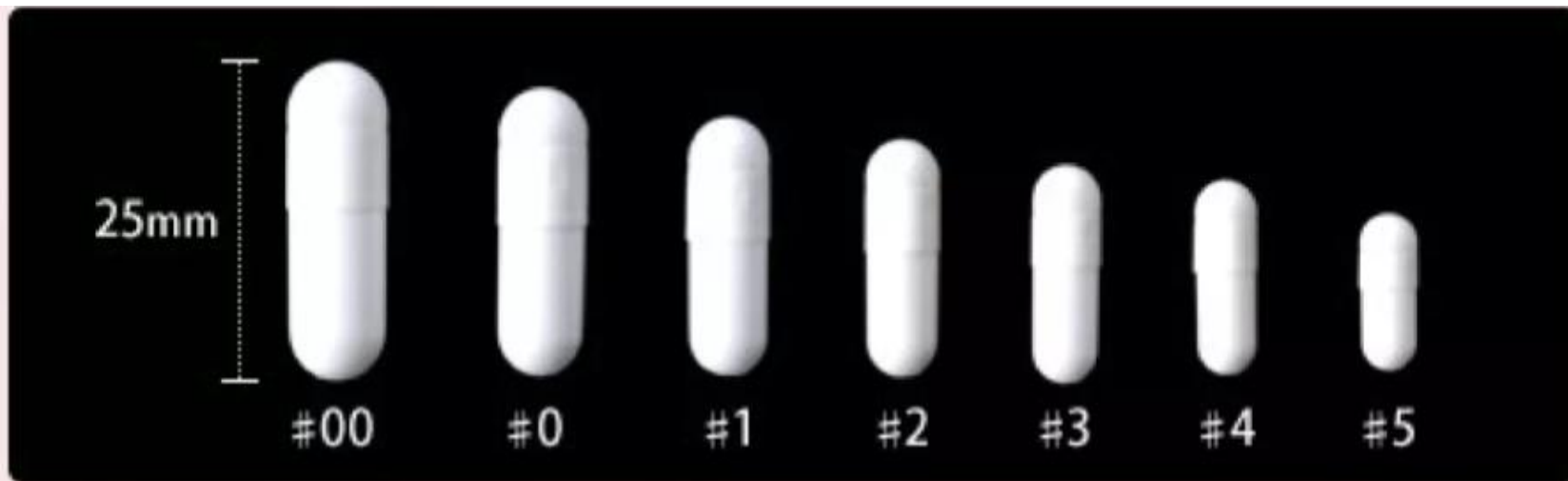

Size	00	0	1	2	3	4	5
Capacity	1.01mL	0.68mL	0.49mL	0.37mL	0.28mL	0.21mL	0.13mL

1- Hard gelatin capsules:

- ❑ The shells of HGCs consist largely of gelatin, sugar & water.



❑ Manufacture:

- The manufacturing machines consist of two parts, which are mirror images of each other: on one half the capsule cap is made and on the other the capsule body.
- The moulds 'pins' دبابيس, are made of stainless steel and are mounted ومثبتة in sets on metal strips, called 'bars'.
- There are approximately 40000 mould pins per machine.

1- Hard gelatin capsules:

1. The tapered rim حافة مدببة → avoids telescoping (faulty join).
2. The Protuberance نتوء → prevent premature opening.
3. The grooves lock the two halves together once the capsule has been filled

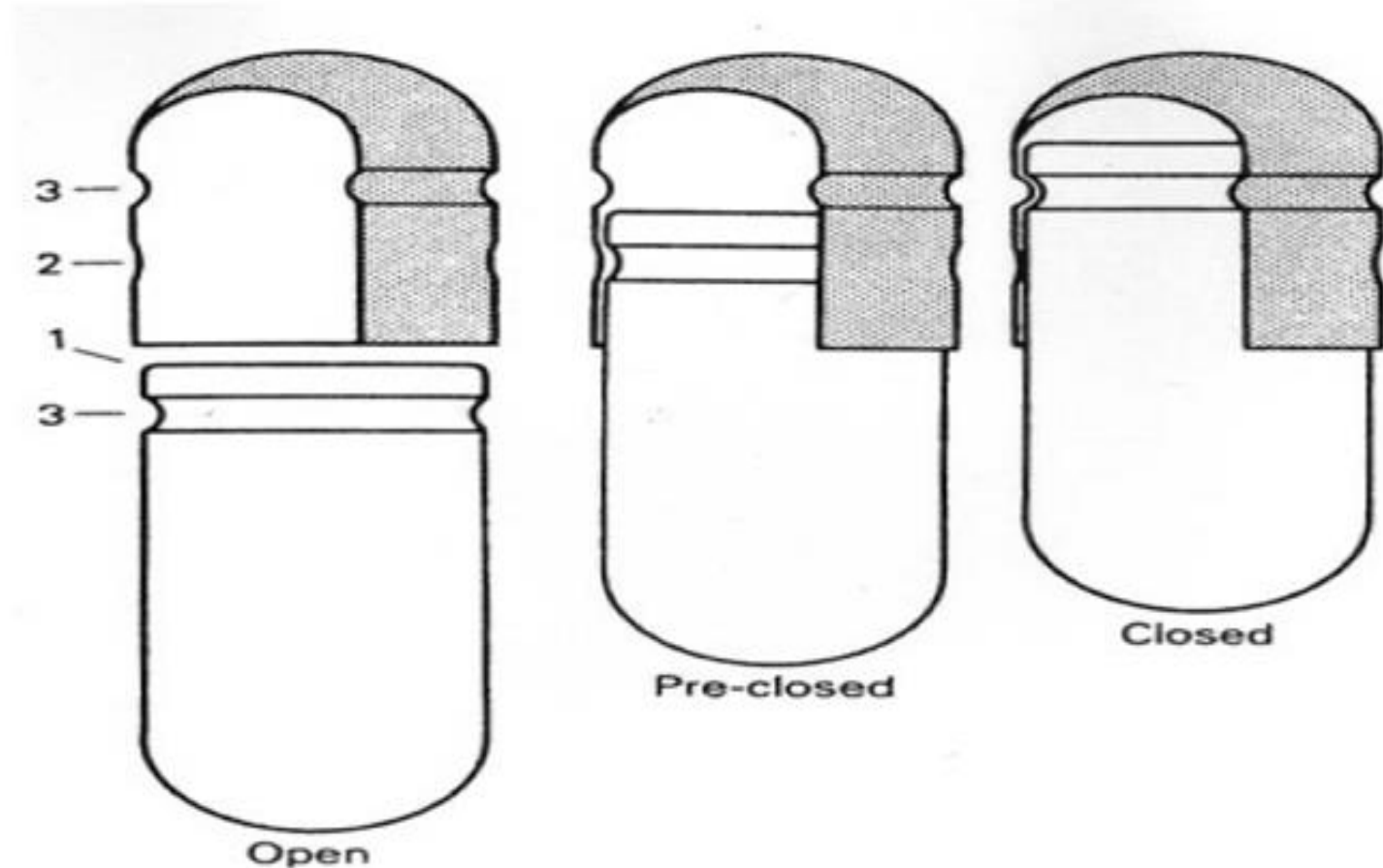

MANUFACTURE



Activate Windc
Go to Settings to act

Hard gelatin capsule manufacture

□ Preparation of gelatin mixture

- Concentrated solution of gelatin (30-45 %) is prepared using *demineralized hot water* (60-70 °C) in jacketed pressure vessels.
 - The solution is stirred until the gelatin has dissolved and then *vacuum* is applied to removed any entrapped *air bubbles*
 - The required amount of *dye solutions, pigment* and others are added
 - The *viscosity* is measured and adjusted to a target value by the addition of hot water
- The higher the viscosity, the thicker the wall produced
- The prepared mixes are then transferred to a *heated holding hopper* on the manufacturing machine

Procedures for production of hard gelatin capsules:

1. Dipping:

- Pairs of the stainless-steel pins are dipped into the dipping solution (melted gelatin mixture) maintained at a constant temperature $\sim 500^\circ \text{C}$ in a heated, jacketed dipping pan to provide the desired viscosity \rightarrow simultaneously form the caps and bodies.

2. Spinning الدوران

- The pins are rotated to distribute the gelatin over the pins uniformly and to avoid the formation of a bead at the capsule ends.

3. Drying

- Gelatin on pins is gently ***dried by flow of cool air*** with controlled temperature and humidity \rightarrow form a hard shell.

Procedures for production of hard gelatin capsules:

4. Stripping: التجريد

- The shells are then *ejected from the pins* → A series of bronze jaws strip the cap and body portions of the capsules from the pins

5. Trimming: زركشة

- The dried shells (cap and body portions) are mechanically *trimmed to the desired length* by stationary knife

6. Joining of capsules:

- The body and cap pieces are *joined* and *ejected* from the machine

The sequence of two-piece hard gelatin capsule shell manufacture

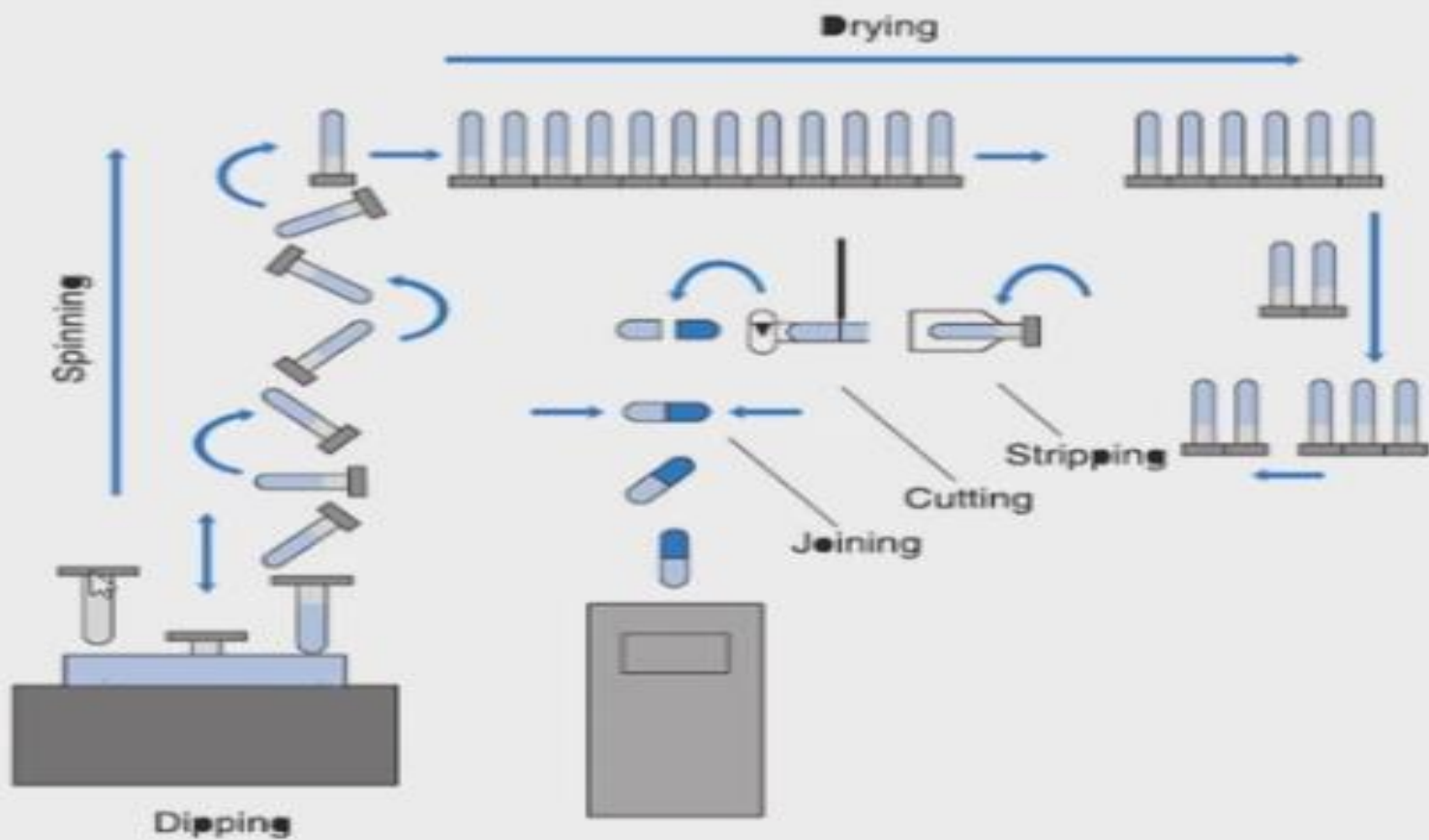



Gelatin
Solution
containers



Dipping



Drying



stripping

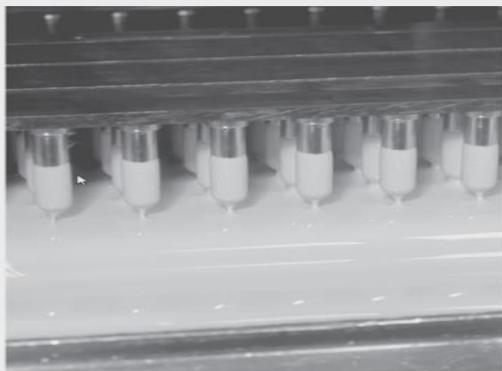

joining



trimming

Properties of the final capsules

- The final capsules should exhibit a water content of **13-16 % w/w**
- Water act as a **plasticizer for gelatin** to ensure the mechanical properties of capsules are sufficient so that the capsule doesn't either crack or permanently deform during manufacture, handling or storage
 - Water less than the specification.....**brittle and crack**
 - Water more than specification.....capsules undergo **plastic flow** when exposed to stress and will **lose the shape**
- Thus, it should be stored at condition that don't adversely affect the water content

Factors affecting geometry of capsules

- Pins dimensions
- Viscosity of gelatin mixture
- Dipping period
- Depth to which the pins are submerged تغمر
- Spinning speed
- Drying program
- Trimmer setting

1- Hard gelatin capsules (Cont.):

Capsule shell filling:

- typically filled with dry solids (powders, granules, pellets, tablets) and semisolids.
- Fixed oils and other liquids that do not dissolve gelatin may be filled into hard gelatin capsules with a pipette or calibrated dropper, then capsules are sealed by moisturizing the lower part of the caps with water.
- Liquids may often be sorbed *ممتص* onto inert carrier powder to form dry powders suitable for capsule filling.

Limitations in properties of materials for filling into capsules:

- Must not react with gelatin e.g. formaldehyde (make the capsule insoluble).
- Must not contain a high level of free moisture (can be absorbed by gelatin causing it to soften).

Filling of Capsules



POWDERS w/ capseal



GRANULES



BEADS



TABLETS

Formulation for filling properties

- *There are three main factors in powder formulation:*
 - Good flow (using free flow diluent and glidant)
 - No adhesion (using lubricant)
 - Cohesion (Plug forming diluent)

Formulation for filling properties

➔ Excipients used for formulation of powder fills

1. Diluents

- The capacity of HGC ~ ranged from 65 to 1000 mg including drug and diluents if necessary
- Therefore, If the amount of the drug to be encapsulated is inadequate to fill the capsule (potent drugs) → addition of diluent is necessary (Also increase uniformity)
- If the amount of the drug is large enough to fill the capsules → a diluent may not be needed
- Lactose and starch are commonly utilized diluent in capsules filling

Formulation for filling properties

Excipients used for formulation of powder fills

2. *Lubricants/glidants*

- glidant ...enhance powder flowability, ***avoid weight variation*** and sticking
- ***Lubricants*** are used to reduce the ***interaction of powder with metal components*** of the filling machine. e.g., Mg stearate (hydrophobic in nature)
 - Increasing conc of Mg. stearate may form oily coating around API and retard dissolution rate so→
 - Using less amount from it (Conc < 1%)
 - SAA may be needed to increase wettability
 - Substitution with ***sod. Stearyl fumarate*** (hydrophilic lubricant).

Formulation for filling properties

Excipients used for formulation of powder fills

3. *Wetting agents*

- ❑ **SAA** employed within powder fill HGCs where the active ingredient is hydrophobic → to increase the *wetting properties of the powder* *ped* flowing release within gastrointestinal tract.
 - Enhance *the uptake of fluid* into the capsule shell.
 - The waterproofing effect of *hydrophobic lubricant* may be offset by use of SAA
 - The most common used SAA in capsules is Sod. lauryl sulphate (1%)

4. *Disintegrants:*

- They also may be added in powder formulations to prevent aggregation and dispersal of capsule in the gut.

Capsule-filling machines:

Three types of capsule filling machines are available:

1. Manual filling method (punch method)

2. *Dependent dosing system*

☐ Hand-operated & semi-automatic capsule filling machines:

- These machines are available in capacities up to 144 capsules and can produce up to 2000 capsules per hour.

3. *Independent dosing system*

☐ Industrial capsule-filling machines (Automatic):

- They are fully automatic machines.
- They are very efficient and can fill hundreds of thousands (165,000)/hr./unit.

1- Hard gelatin capsules (Cont.):

Methods of filling capsules

(1) manual (punch) filling:

- Used for filling a small number of capsules in the pharmacy, at the prescription counter.

The powder to be encapsulated is placed on a sheet of clean paper or a glass or porcelain plate.

with a spatula is formed into a cake having a depth of one fourth the length of the capsule body.

The cap is replaced and the filled capsule is weighed using an empty capsule of the same size as a tare.

The cap is removed, and the empty capsule body is held between thumb and forefinger *والسبابة والإبهام* and repeatedly punched downward (vertically) until it is full.

1- Hard gelatin capsules (Cont.):

Punch Method

Used when filling a small number of capsules.



1- Hard gelatin capsules (Cont.):

Filling Machine Operation

The filling machine must undertake five basic operations :

- (1) **Rectification** The capsules must first be positioned so that the cap and body can be easily separated.
- (2) **Separation** The caps and the bodies must be separated so that the body can be filled with the active ingredient.
- (3) **Filling** The active ingredient is administered to the body using pistons, augers, tamping devices and other mechanisms.
- (4) **Joining** The cap and the body are rejoined in the snap-lock position so that none of the fill escapes.
- (5) **Ejection** The filled capsule is ejected from the machine.

Hand-operated capsule filling machines:

- Pharmacists that prepare capsules on a regular or extensive basis may use hand-operated capsule machines
- It is having following parts:-
 1. Bed having 200-300 holes.
 2. Loading tray having 200-300 holes.
 3. Powder tray.
 4. Pin Plate having 200-300 pins.
 5. Sealing plate having rubber top.
 6. Lever
 7. Cam handel

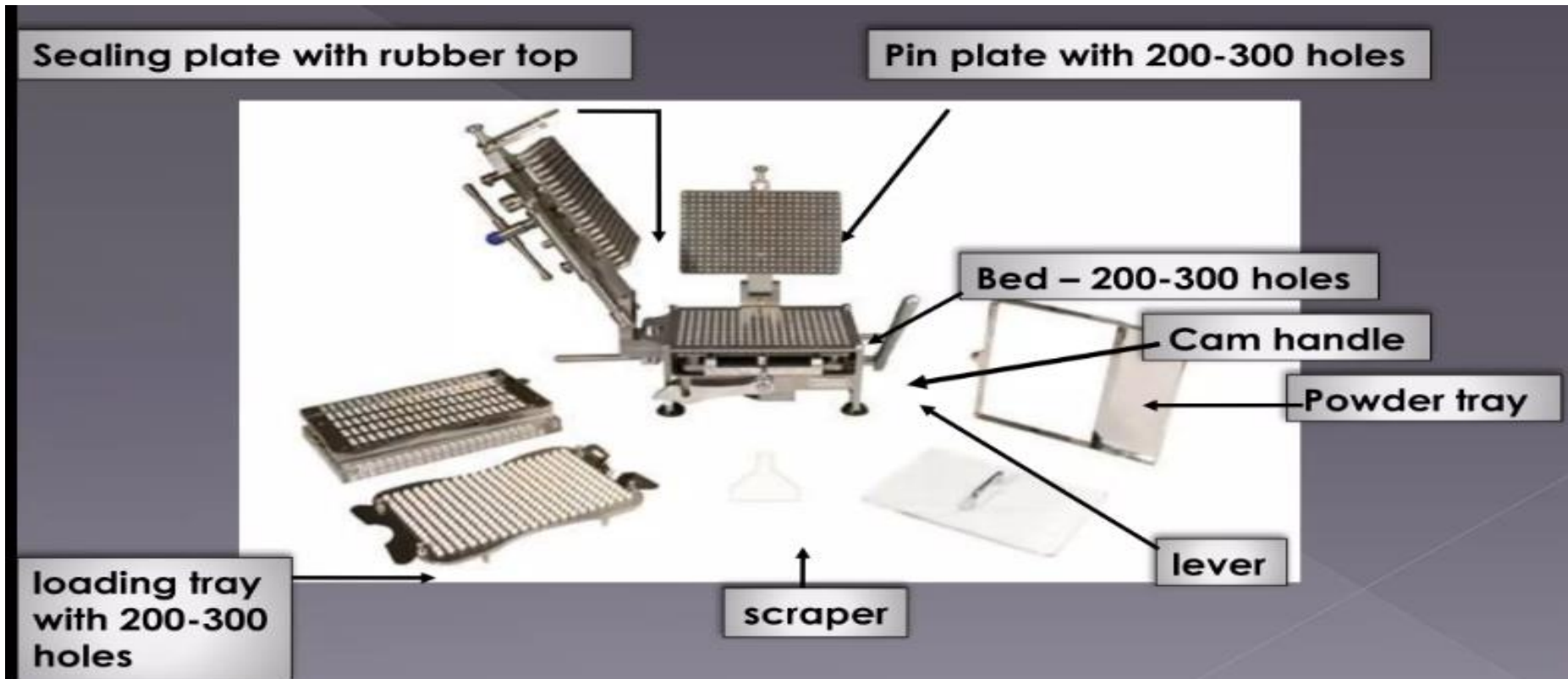

Hand-operated capsule filling machines:

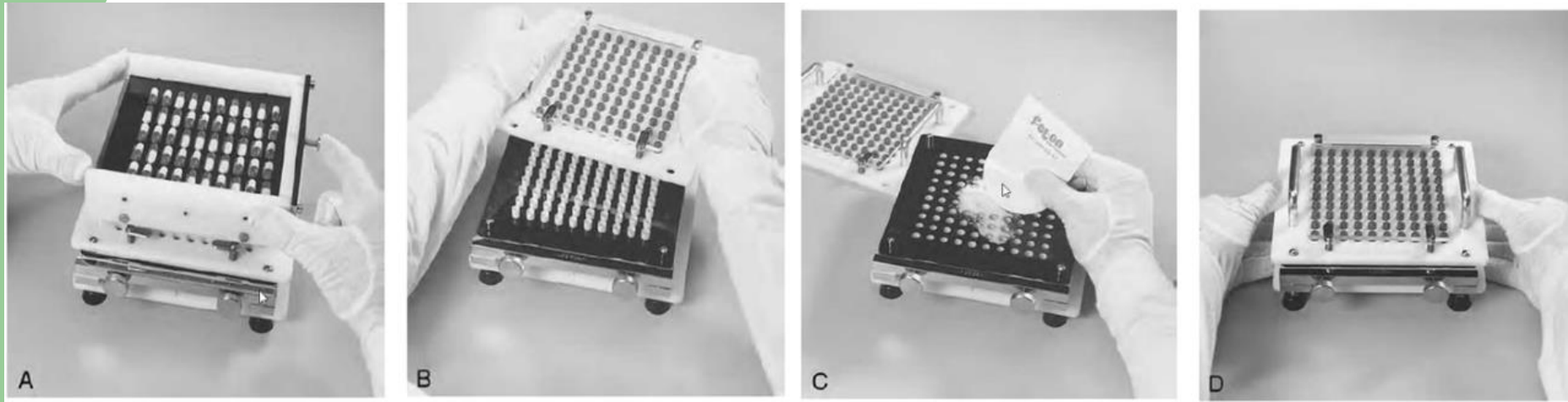

- A. With empty capsules in the loader tray, → the tray placed on the top of the filler unit.
- B. The loader inserts the capsules into the filling unit and is removed, and the top plate is lifted using locking lever to separate the caps from the bodies.
- C. Place powder tray on the filler, → The powder is placed on the unit, and the capsule bodies are filled. Turn the handle, to compress the powder, allow more powder filling
- D. The top plate is returned to the unit, and the cap are placed on filled capsule bodies.

Semiautomatic filling machines

Auger مثقب *feeding system*

Principle

- Powder or granules are contained in mass flow hoppers with rotating augers.
- Powder is fed continuously out of the hopper outlet due to the rotation of the auger.

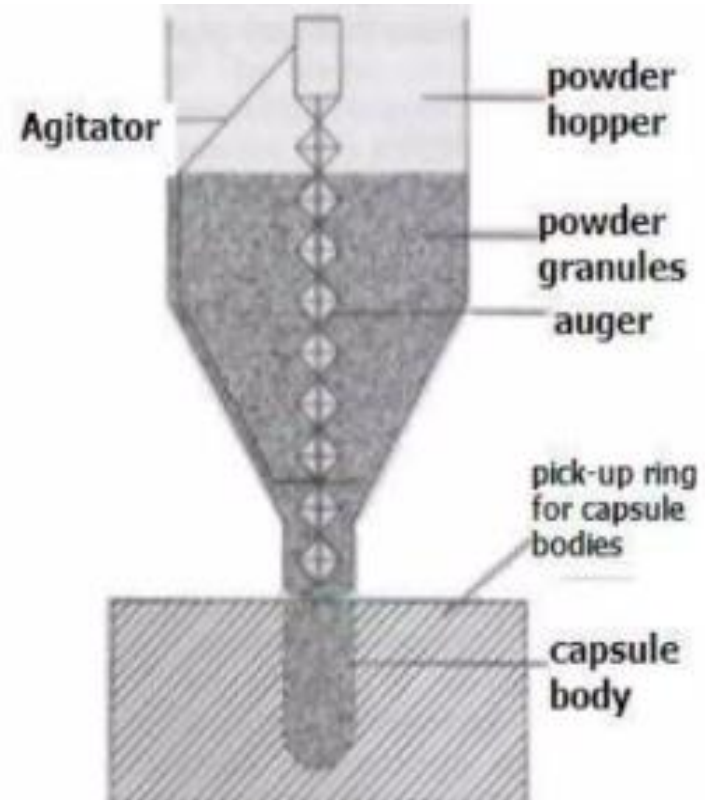
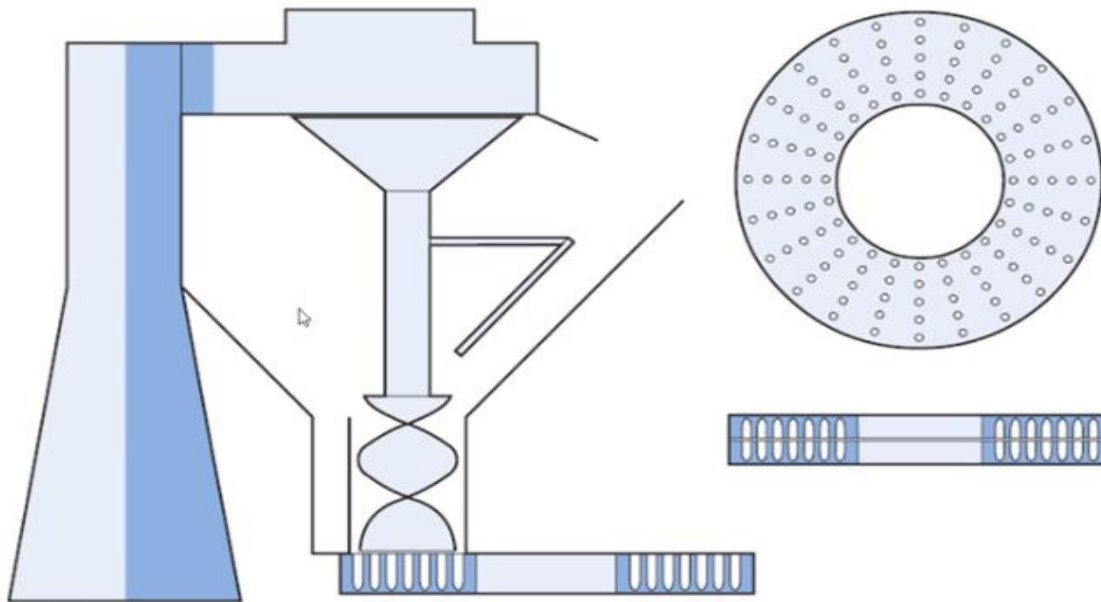



**EMPTY
CAPSULE**

**ORIENTATION
AND SEPARATION
OF CAPSULE**

**POWDER
FILLING**

**CAPSULE
CLOSING**

**FINISHED
CAPSULE**

1- Hard gelatin capsules (Cont.):

Flow diagram for Gelatin Capsule

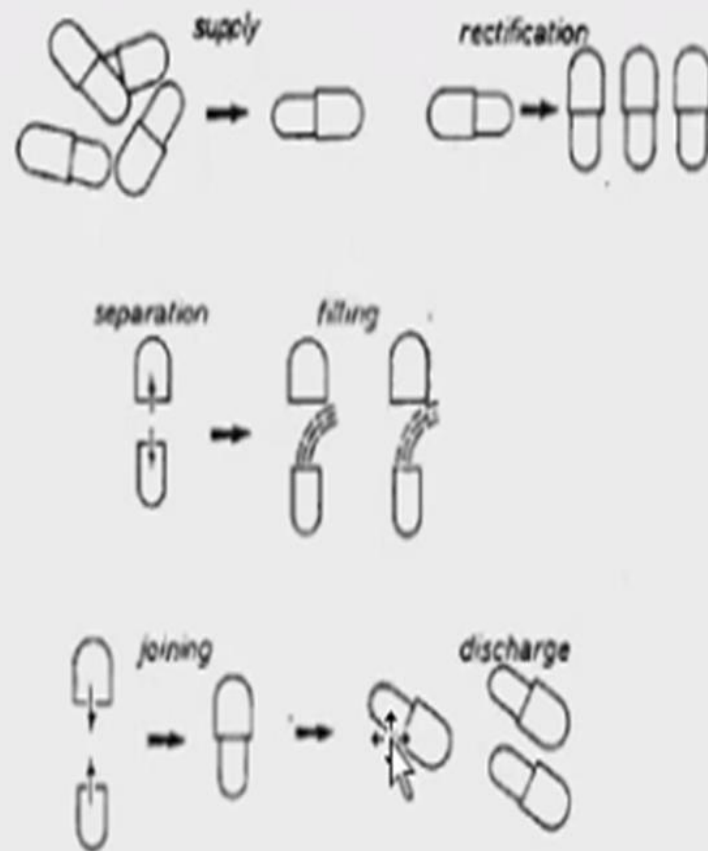
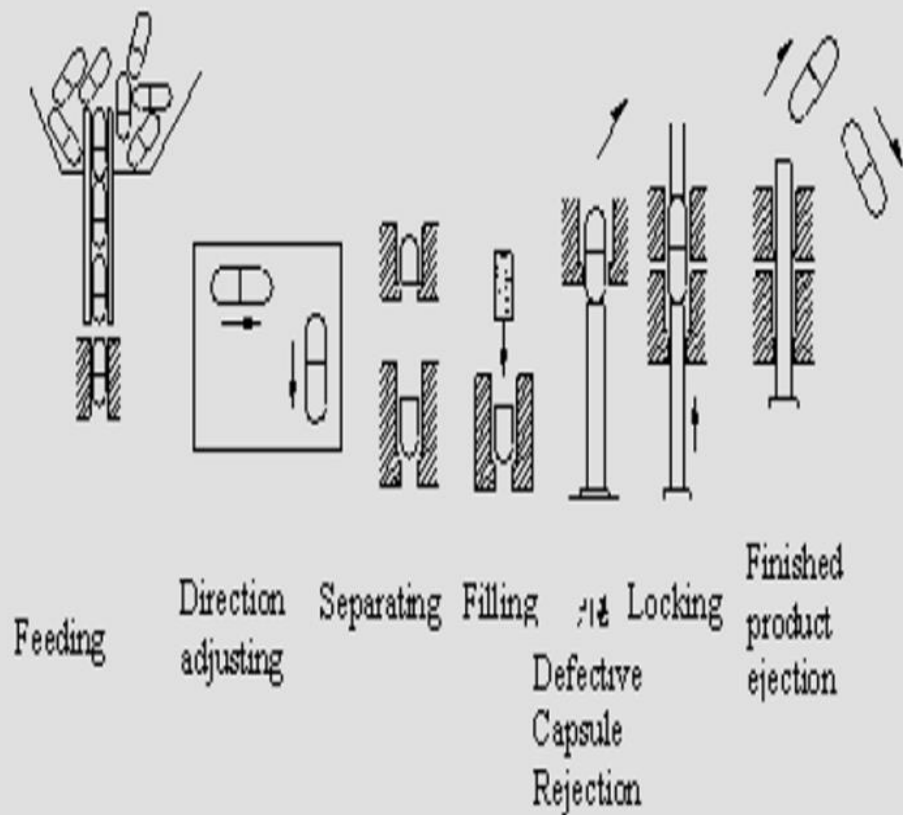

KDF-2 semi-Automatic Capsule filling machine (Vertical type)

- There are 3 station in this semi-automatic capsule filing machine.
 1. Orientation of capsule
 2. Powder filing
 3. Capsule closing

TECHICAL DATA

Capacity:	Max. 25,000 Pcs/HR
Power Supply:	AC 220/380V, 50/60Hz
Power	Machine 1-1/4 HP
Consumpt	Hydrolic 1 HP
ion:	Vacuum 2 HP
Machine Size	167cm x 102cm x 164cm



KDF-2 semi-Automatic Capsule filling machine (Vertical type)

1. Orientation of capsule

- Feeding, aligning المحاذاة and insertion of capsule into perforated capsule filling ring
- The ring is rotated on a turntable, and a vacuum separating the cap and body.
 - Cap can stay in the upper holding ring
 - Where body can stay in lower holding ring.

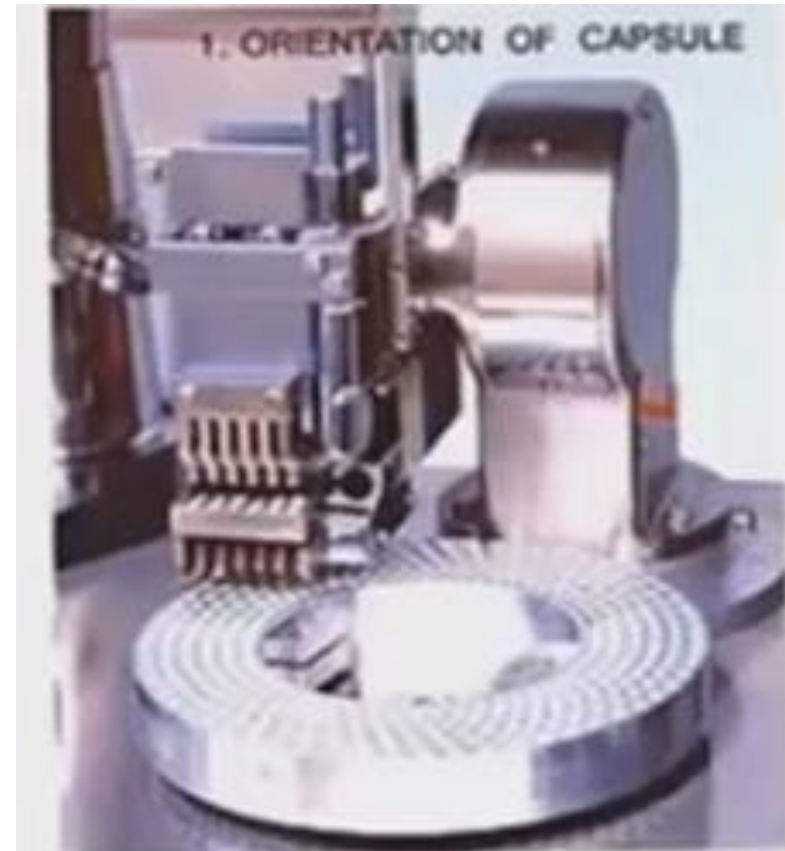

2. Powder Filling

- Separating the holding ring manually, → the cap half of the ring is set aside.
- The lower holding ring having capsule body is then put on rotary table where it is rotated mechanically under a powder hopper.
- pull the powder hopper over the lower (body) holding ring, → in hopper, the revolving auger start to run → **Fill the powder down** into the capsule body
- The weight of powder filled in the body **dependent mainly upon:**
 - The time the body underneath the hopper during revolving of plate holder



KDF-2 semi-Automatic Capsule filling machine (Vertical type)

3. Capsule Closing

- Put the upper & lower holding ring together.
- Take the holding ring a head of ejector and aim ejector at the bores of holding ring.
- Use hydraulic cylinder to push ejector and let it press capsule for closing.
- Push Capsules inside the bores of holding ring out, → capsules collected into the container





Hard gelatin capsules (Cont.):

(2) Industrial filling:

- a. removal of caps,
- b. filling of the bodies,
- c. replacement of caps, and
- d. ejection of filled capsules.

- The industry uses semi-automatic and fully automatic equipment for the large-scale filling of capsules.
- The semi-automatic machine is capable of filling all capsule sizes from 000 through 5 and attains its maximum rated capacity of 15,000 capsules per hour.

Tamping finger and dosing disc

Tamp principle:

- These piston tamps alter the shape of powder by compressing the powder to form slugs. →
- These slugs are transferred into the empty capsule bodies with the application of slight pressure. →
- Finally, the bodies are ejected from the machine
- Dosator type machine
- dosing disc type machine

Dosator type machine

- Most frequently used type in industry

Dosator principle:

- It consists of open-ended cylindrical dosing tube fitted with movable piston.
- The open end is placed in bulk powder.
- Powder enters the open end of dosator and is slightly compressed against the piston into a slug
- The assembly is then raised from the powder bed and positioned over the capsule body
- The piston is lowered, ejection the powder plug into the capsule bodies

Dosator type machine

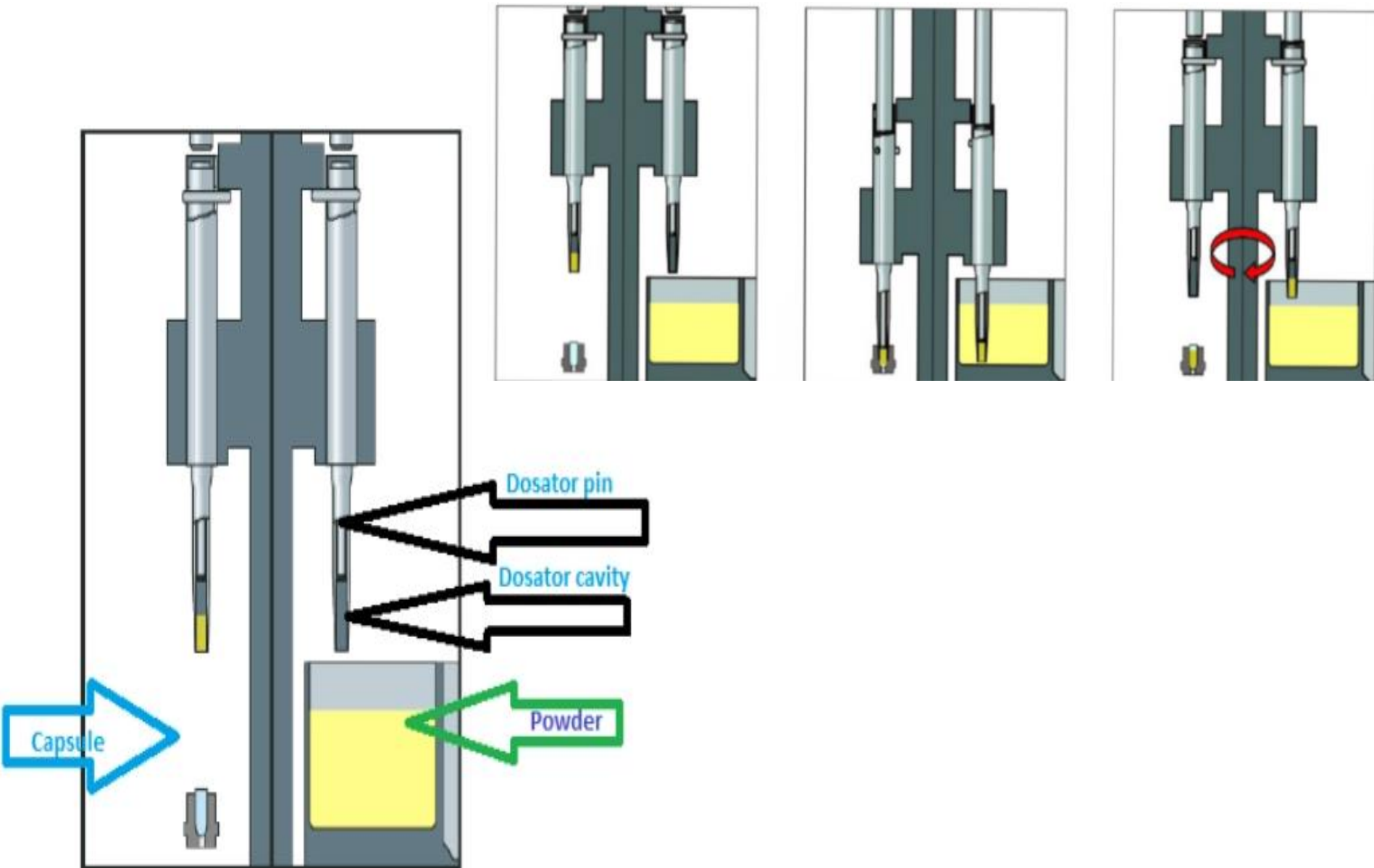

➤ *The weight of powder fill can be adjusted*

- By altering the position of the piston inside the tube i.e., increasing or decreasing the volume
- Changing the depth of powder bed



<https://www.youtube.com/watch?v=EbCHRoMvogg>.

<https://www.youtube.com/watch?v=dSaaT4wrXuc>.

LEOSCOP Fully Automatic Capsule Filling Machine
capable of filling upto 50,000 capsules per hour

Tamping finger and dosing disc

principle:

- The *dosing disc* forming the bottom of revolving powder hopper
 - five sets of pistons compress the powder into cavities to form plugs –
 - At each position, the fingers push materials into holes, building up a slug before they index on the next position.
 - At the last position the finger pushes the plug through the disc in to capsule body
- The powder fill weight can be varied by the amount of insertion of the fingers into the disc, by
 - changing the thickness of dosing disc
 - Adjusting the amount of powder in the hopper
- EX. Hofliger and Karg manufactured by Robert Bosch and Shionogi Qualicaps F-80
- All types are intermittent motion

<https://www.youtube.com/watch?v=FADerVQ-tPg>
<https://www.youtube.com/watch?v=Hug7SeTVFhk>

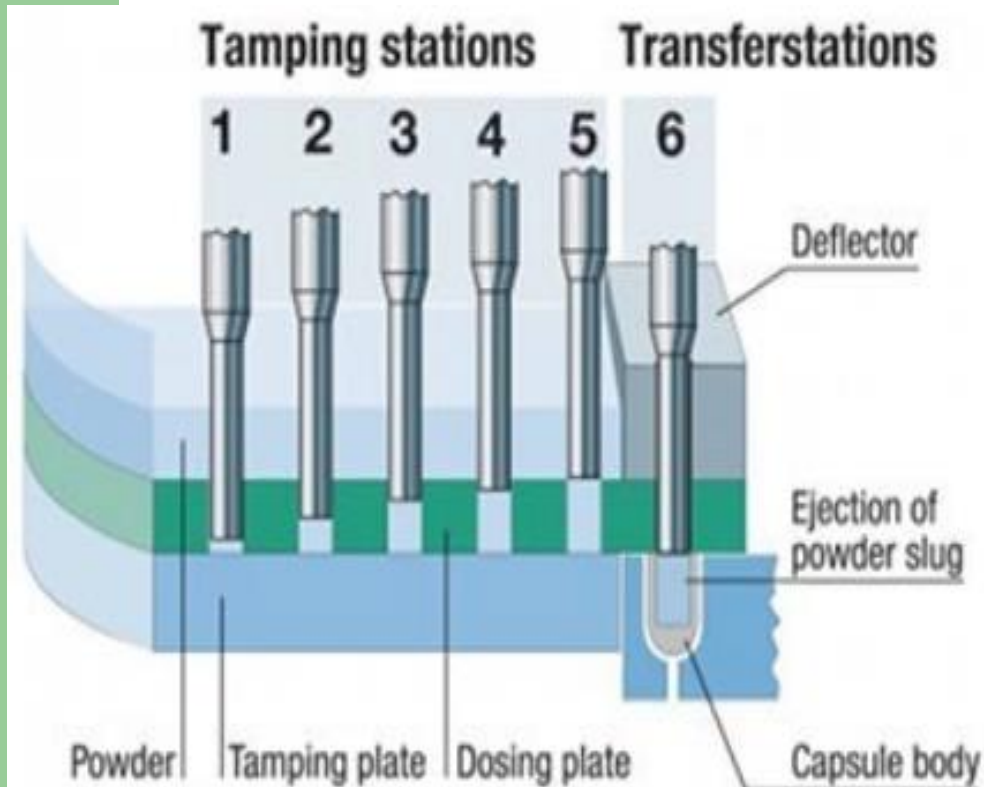

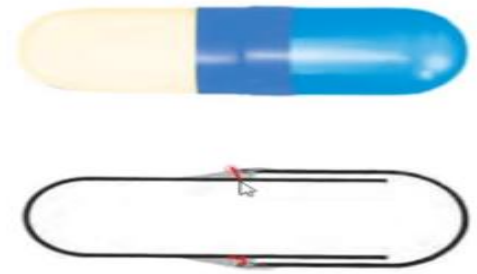

Sealing and finishing operation of HGC

- Finishing operation in HGC production involves three steps:

I. Closure or Sealing of hard gelatin capsules:

1. *Grooving*:

- grooves molded in the cap and body portion to provide a positive closure when they are fully engaged
- Grooving prevent an accidental separation of the filled capsules during shipping and handling

2. *Welding* (اللاحام):

- positive closure obtained by spot fusion of the cap and body through thermal means or ultrasonic energy

- #### 3. *Banding*: Placing one or more layer gelatin color bands at the meeting point of the same caps and the bodies.

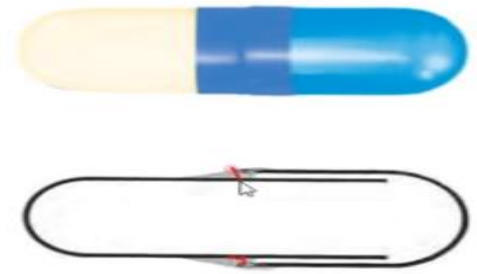

Sealing and finishing operation of HGC

I. Closer or Sealing of hard gelatin capsules:

3. Liquid fusion process:

- Filled capsules → The inner surface of caps are wetted with a hydroalcoholic solution, → which penetrate into the space where the cap overlap the body followed by drying
- The last two techniques are applied for completely sealing the HGCs in large scale production and have the following advantages:
 - Improve the stability of the content by limiting oxygen penetration
 - Employed when semisolid or non-aqueous liquids are encapsulated to prevent leakage.

2. Cleaning and polishing of HGCs

Small Scale

capsules may be cleaned

- individually in small numbers by rubbing them with a clean gauze or cloth

Large Scale

Many capsule-filling machines are affixed with

- A cleaning vacuum that removes any extraneous material from the capsules as they exit the equipment. *Acela-cota pan*

Cleaning and polishing of HGCs

- ❑ ***Vacuum cleaning.*** In large scale, many capsule filling machines are equipped with a cleaning vacuum that removed the extraneous material from the capsule shell.
- ❑ ***Cloth dusting.*** On small scale, rubbing them with clean cloth may or may not wetted with suitable oil
- ❑ ***Salt polishing.*** The filed capsules and NaCl are rotated in container similar to tablet coating pan
- ❑ ***Brushing.*** Capsules are fed under soft rotating shaft brushes which remove the dust from the capsule shells.

Vacuum Cleaning



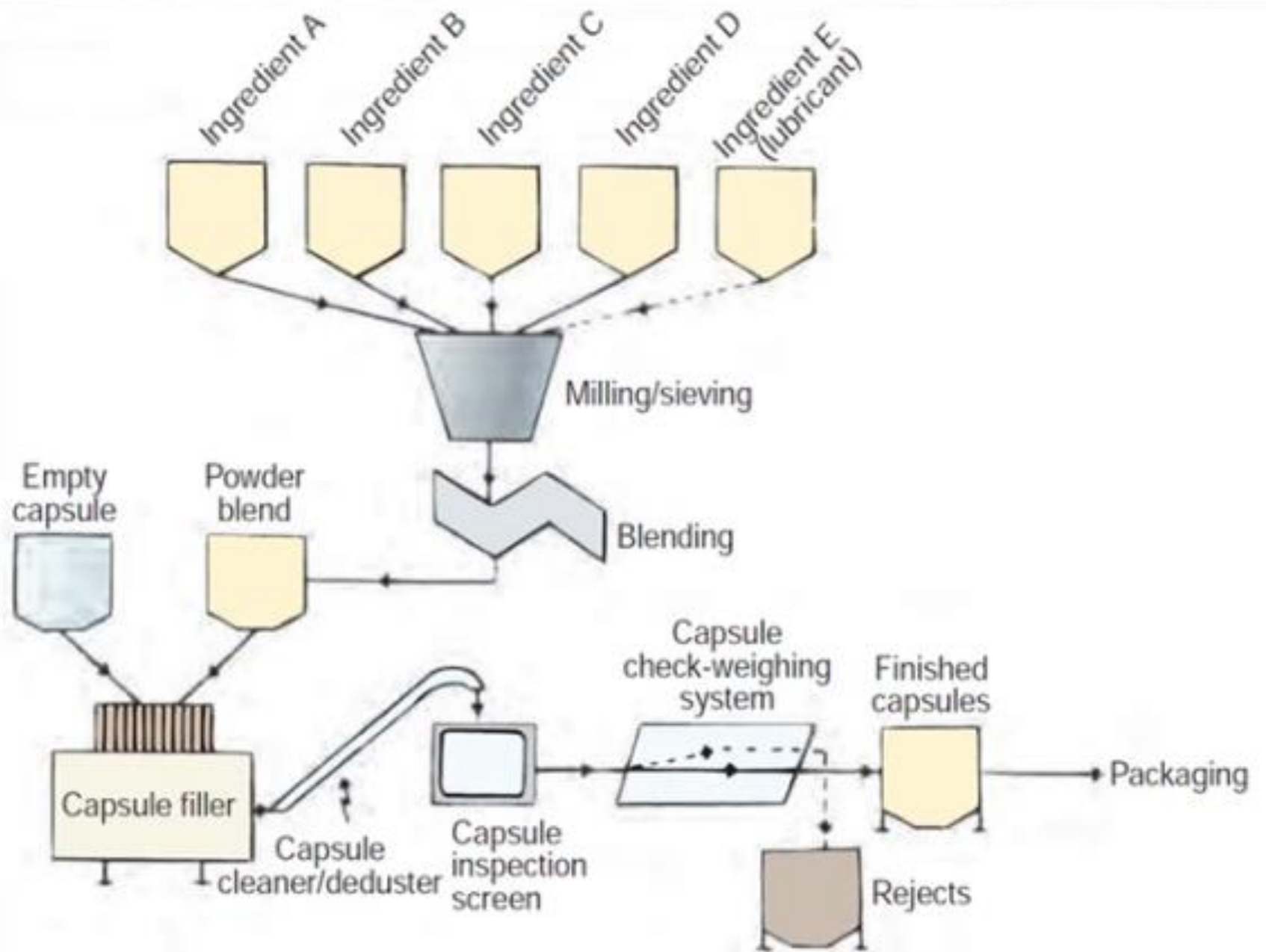

- The HGCs can be filled with a variety of materials which include:

1. powder or granules
2. Pellet mixtures
3. Paste
4. Small capsule
5. tablet

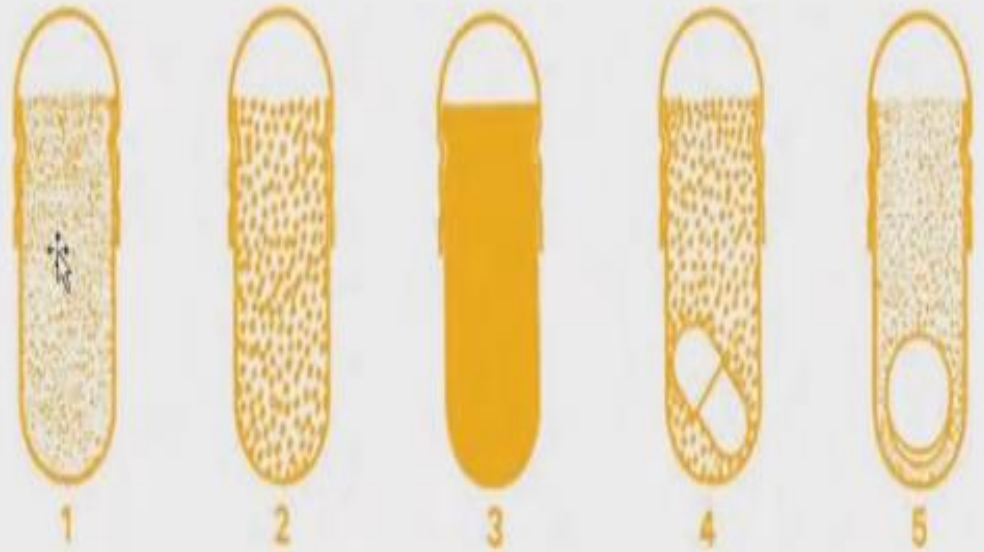

Examples of fill in hard gelatin capsules. 1, powder or granulate; 2, pellet mixture; 3, paste; 4, capsule; and 5, tablet

Storage Hard gelatin capsules:

- Finished capsules normally contain an equilibrium moisture content of 13-16%.
- Store in tightly closed glass container at RH 35-45% and Low temperature not exceed 25 °C
- They should not be exposed to conditions of extreme high or low humidity because:
 - Under **high humidity**: Capsules may absorb additional moisture, and this may render **them stick, soften and deformed**.
 - Low humidity or high temperature → loss of water → brittle and fragile
 - Since hard gelatin capsules are of animal origin, they should be protected from sources of microbial contamination.

Problems encountered in HGCs

- ***Eutectic mixture***: They are of two or more substances which has the lowest melting point known as eutectic point. e.g. . Camphor-Salicylic acid mixture
- Eutectic mixture can be dispensed in three methods:
 - Each of mixture ingredients is kept separately and mixed with inert absorbent powder such as kaolin or light mg. Oxide or mg. carbonate
 - The mixture components are mixed to form eutectic intentionally, then mixed with inert absorbent powder
 - Each ingredients is wrapped separately and mixed directedly before use

Problems encountered in HGCs

❑ *Deliquescent powder:*

- capsules contain delinquent powder should be dispensed in tight closed container with absorbent such as mg. Carbonate, colloidal silicon dioxide or suitable adsorbent.

❑ *Separation of incompatible materials:*

- The separation can be achieved by placing one in small capsule and then enclose it with the second material in large capsule.

❑ *Accuracy in weighing potent drug:*

- Adding an inert powder to the drug will increase the bulk to be weighed and increase accuracy of weighed materials

Problems encountered in HGCs

Massed ingredients and liquid:

- Semi solid may be formed by gelling liquid drug or vehicle with colloidal silica or powdered with high molecular weight PEG.
 - Various fatty or waxy components may be used to prepare semisolid matrices by fusion.
 - Semisolid or viscous liquid that can not be powdered e.g. Glycyrrhiza may be massed with powder

2- Soft gelatin capsules:



- soft elastic (softgel): Consist of a hermetically one-piece soft gelatin shell containing a liquid, suspension or a semisolid core.
- Formed, filled, and sealed in one operation.
- Oblong, spherical, elliptical in shape.
- The capsule shell consists of gelatin (35-45 %), water (5-8 %), sucrose (Up to 5%) and plasticizer (15-25%).
 - *Plasticizer makes the shell elastic.
 - *e.g. Glycerol, sorbitol and propylene glycol.
- Similar to HGCs may contain colorant, opaquing agent, flavoring agent and preservative

2- Soft gelatin capsules (Cont.):

Advantages:

1. Patient compliance and preference, easy to administer
2. Improved drug absorption. → by introduction of the drug in solution form → led to higher absorption rate than solid oral dosage forms specially for poor soluble drugs
3. **Increase bioavailability**: Bioavailability of drugs administered by softgels >>> those of hard gels
4. Overcome problems with manufacture (e.g. oils, low melting point drugs) as compressed tablet.
5. Dose uniformity for low-dose drugs (**potent drugs**) → liquid dosing avoid powder poor flowability and so give good content uniformity

2- Soft gelatin capsules (Cont.):

Advantages:

5. Good product stability→ low oxygen permeability, low moisture content will protect the drugs against oxidative degradation by lipid vehicles and gelatin shells.
6. Safety – avoids dust handling problems during manufacture and better operator safety.
7. Specialized dosage forms can be made. e.g. chewable, extended release.
8. Elegance
9. portable

2- Soft gelatin capsules (Cont.):

Disadvantages:

1. Soft gelatin capsules are not easily prepared except on a large scale and with specialized equipment.
2. They are an expensive dosage form, when compared with direct compression tablets.
3. There is a more intimate contact between the shell and its liquid contents than exists with dry-filled HGCs, which increases the possibility of interactions.
4. Substances that soften, dissolve or easily migrate through the softgel shell can not be formulated as softgels. e.g. Water, alcohol, LMW water soluble materials

Types of softgels according to the models of drug delivery:

- 1. Orally administered** : containing solutions or suspensions that release their contents in the stomach in an easy way to swallow.
(most common.)
- 2. Chewable** : a highly flavoured shell is chewed to release the drug liquid fill matrix. Used to encasing لتغليف nutraceuticals, vitamins, nutritional supplements.
- 3. Suckable** : consist of a gelatin shell containing the flavoured medicament to be sucked and a liquid matrix (or just air inside the capsule).

Types of softgels according to the models of drug delivery:



4. *Twist-off*: designed with a tag **بعلامة** to be twisted or cut off, thereby allowing access to the fill material.

→ It can be very useful for unit dosing for oral pediatric product, inhalations, or cosmetic products, e.g skin (revitalizer **منشط**) and hair care products.

5. *Meltable* **قابل للذوبان** designed for use as 'patient-friendly' pessaries or suppositories



2- Soft gelatin capsules (Cont.):

Types of fill matrixes:

- Lipophilic liquids / oils: e.g. soya bean oil.
- Hydrophilic liquids: PEG400.
- Self-emulsifying oils (oil + non ionic surfactant).
- Microemulsion and nanoemulsion systems.
- Suspensions.

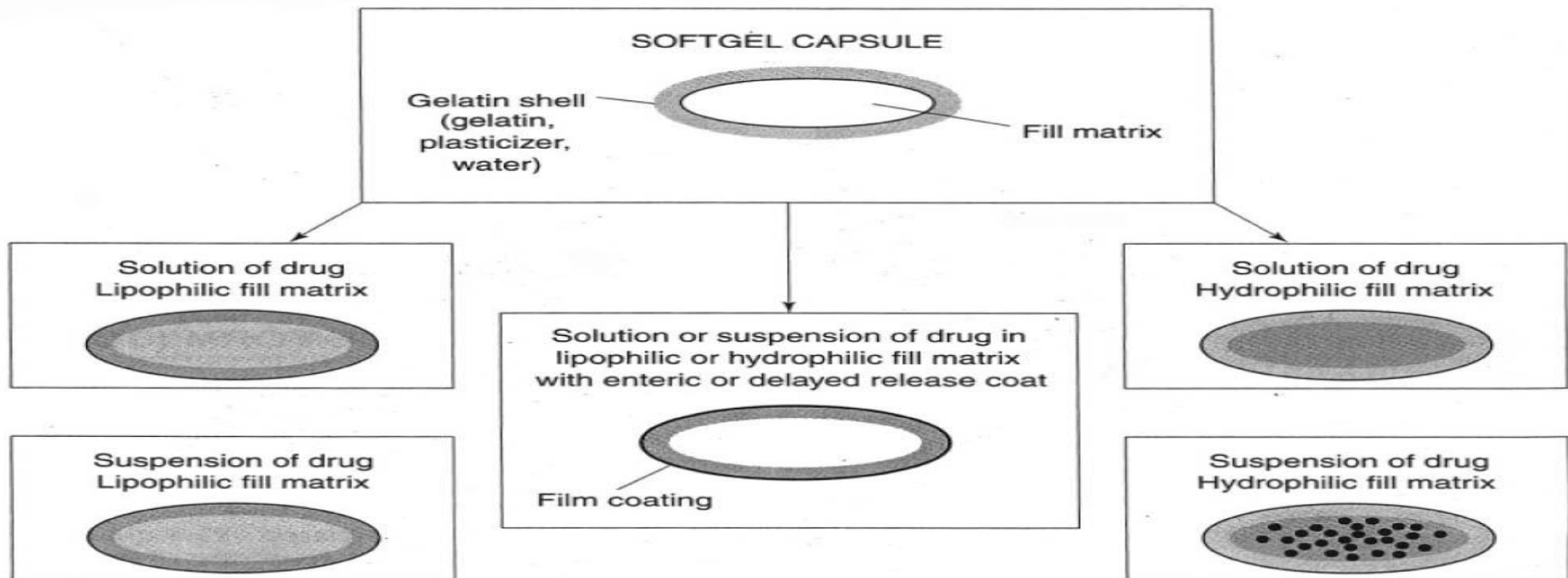

Formulation of Softgels

- A typical gel mass formula for making soft gelatin capsules would be:
 - Gelatin 35-45%
 - Plasticizer 15-25% (glycerin or sorbitol)
 - Water ~40%
 - Dye / Pigment as needed
 - Opacifier as needed
 - Other (flavour, sugar,) as needed 43



Manufacture of Softgels

Manufacturing methods:

1. Plate process
2. Rotary die process
3. Seamless Bubble method
4. ACCOGE1

<https://www.youtube.com/watch?v=WxgRebEt1qk>.

Rotary Die Process

- In this machine the soft gelatin capsules are prepared & then filled immediately with liquid medicaments.
- It is having two hoppers & two rotating dies.

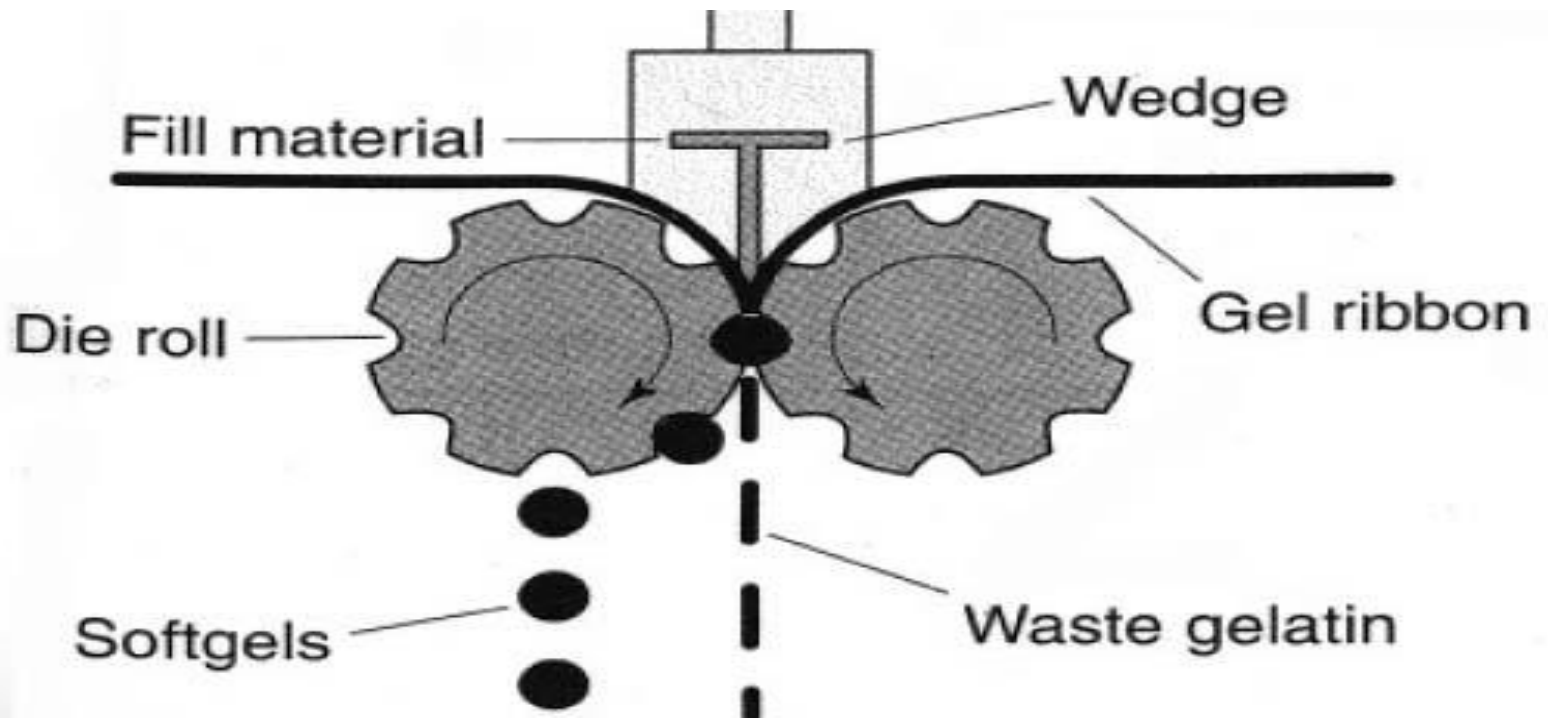

Rotary Die Process

Procedure:

- Gelatin + water → gel mass then plasticizer (as glycerol) is added.
- Liquid mixture is placed in one hopper & the liquid medicament in another Hopper.
- The two rotating dies rotate in opposite directions when the fluid gelatin mixture enters the machine from the hopper it produces two continuous ribbons .
 - These half shell of the capsule is formed.
 - At this stage the measured quantity of the medicament is filled in to it with the **stroke of a pump مضخة** with the subsequent movement of the dies the other half capsule is formed.
- The two halves' of the capsules are sealed together by the application of heat & pressure of the rotating dies.
- As the die rolls rotate, the convergence **التقارب** of the matching die pockets seals and cuts out the filled capsules

Rotary Soft Gelatin Capsule Filling Machine

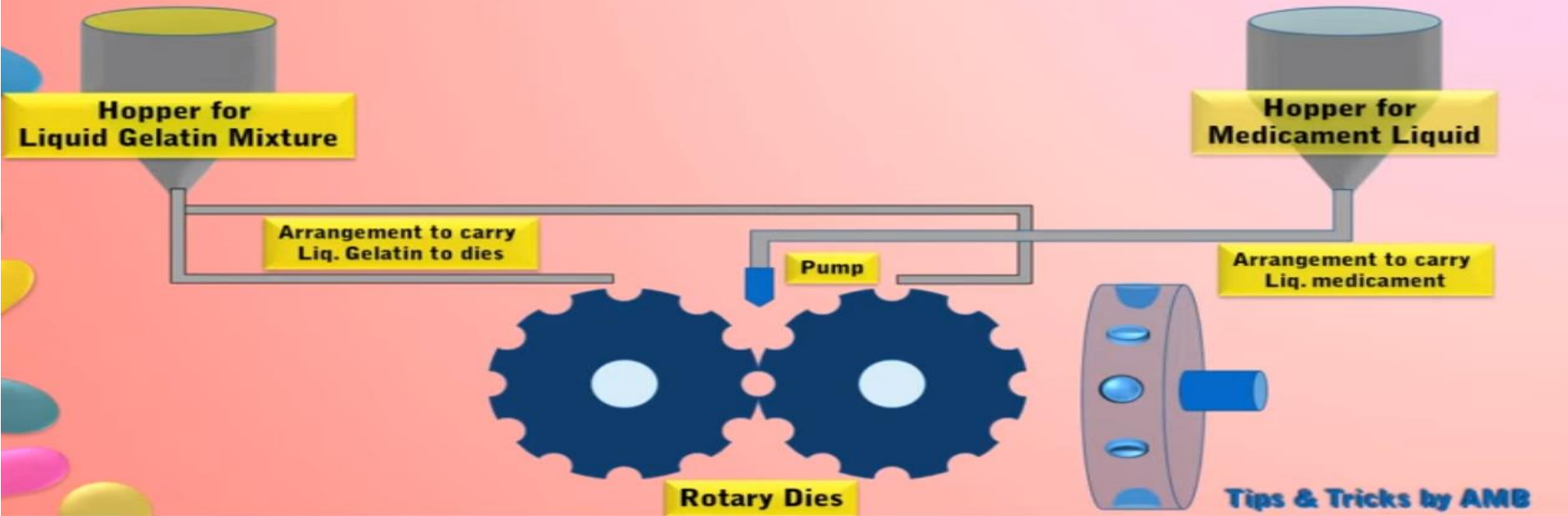

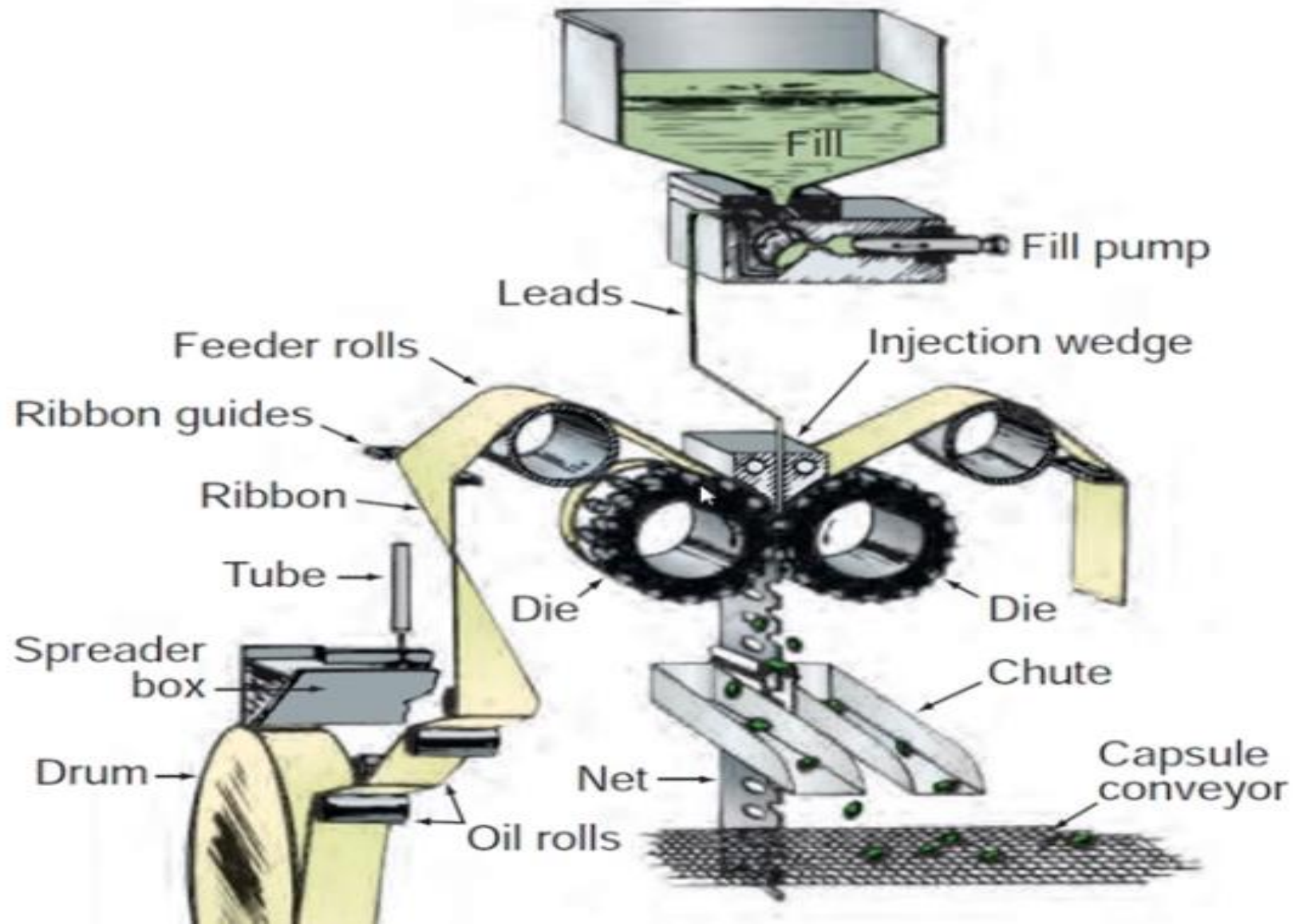

■ Control of rotatory die process

- ❑ **Temperature:** control the heat available for capsule seal formation
- ❑ **Timing:** The time available for dosing unit quantities of fill matrix is critical
- ❑ **Pressure:** The pressure exerted between the two-rotatory dies control the **softgel shape and the final cut-out** from gel ribbon

■ In-process testing:

- Gel ribbon thickness (mainly 0.5-1.5 mm)
- Softgel seal thickness at time of encapsulation
- Fill matrix weight
- Capsule shell weight
- Shell moisture content
- Shell hardness at end of drying

Accogel capsule machine

- In general, this is like rotary process. It consists of mainly 3 parts:
 1. Measuring roll
 2. Die roll
 3. Sealing roll
- Measuring roll rotate directly over the die roll
- As the measuring roll and die rolls rotate, the measured doses are transferred to the gelatin-linked pockets of the die roll.
- The continued rotation of the filled die converges with the rotating sealing roll where a second gelatin sheet is applied to form the other half of the capsule.
- Pressure developed between the die roll and sealing roll seals and cuts out the capsules

Fill Material (powder or granular) is held in the pockets of the measuring roll under vacuum)

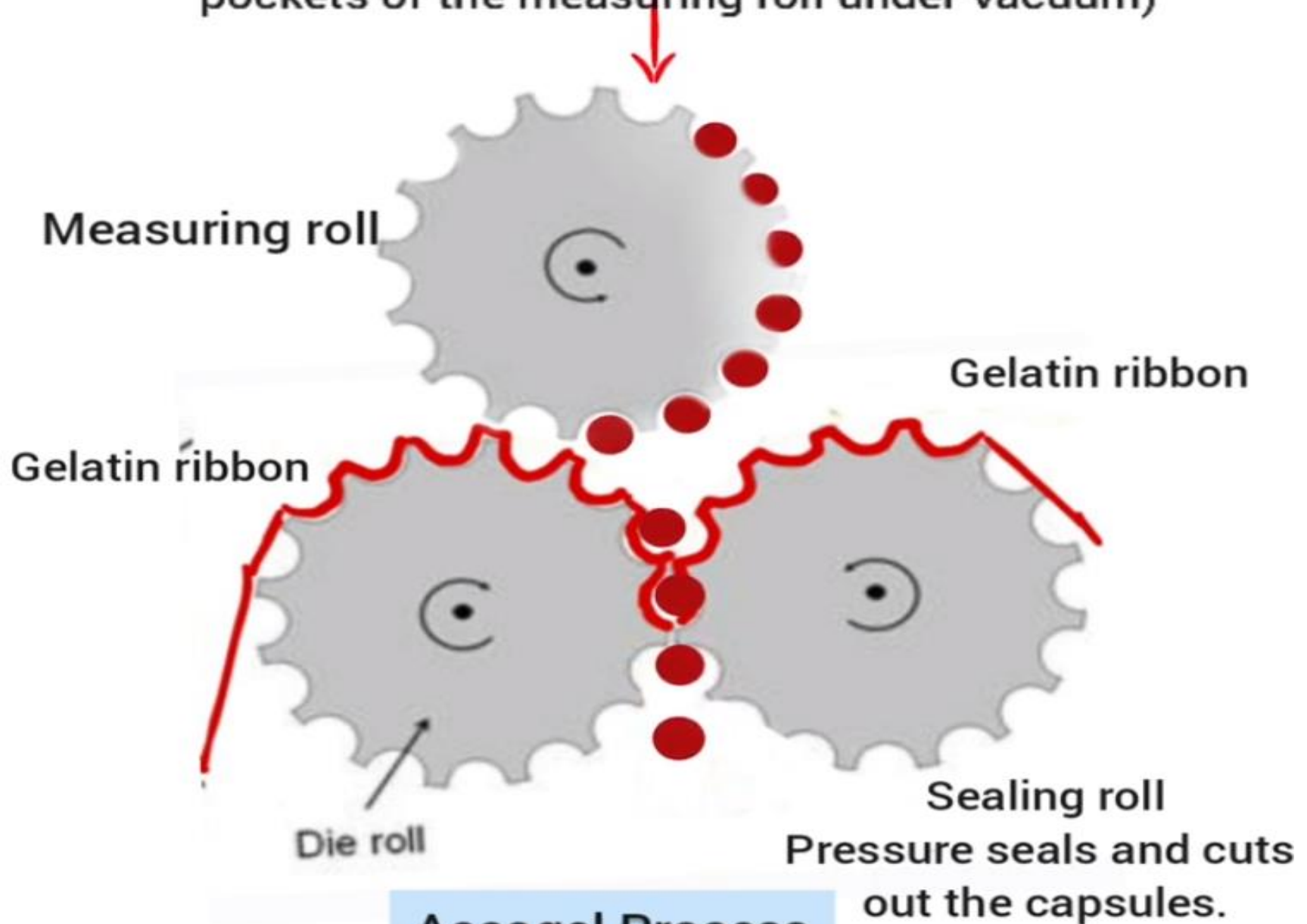

Accogel Process

2- Soft gelatin capsules (Cont.):



Seamless gelatin capsules:

- It is a modern method for making soft gelatin capsules.
- The essential parts of the apparatus consist of two concentric متحدة المركز tubes.
- Through the inner tube flows the medicament, and through the surrounding outer tube, the gelatin solution.
- The medicament, therefore, issues يخرج from the tube surrounded by gelatin and forming a spherical drop. → This is insured by allowing the drop to form in liquid paraffin in which the gelatin is insoluble.
- Droplet assumed spherical shape under Surface Tension force and gelatin congeal on cooling
- The capsules are subsequently degreased إزالة الشحوم and dried.

<https://www.youtube.com/watch?v=ok0fEwU8yRg>.

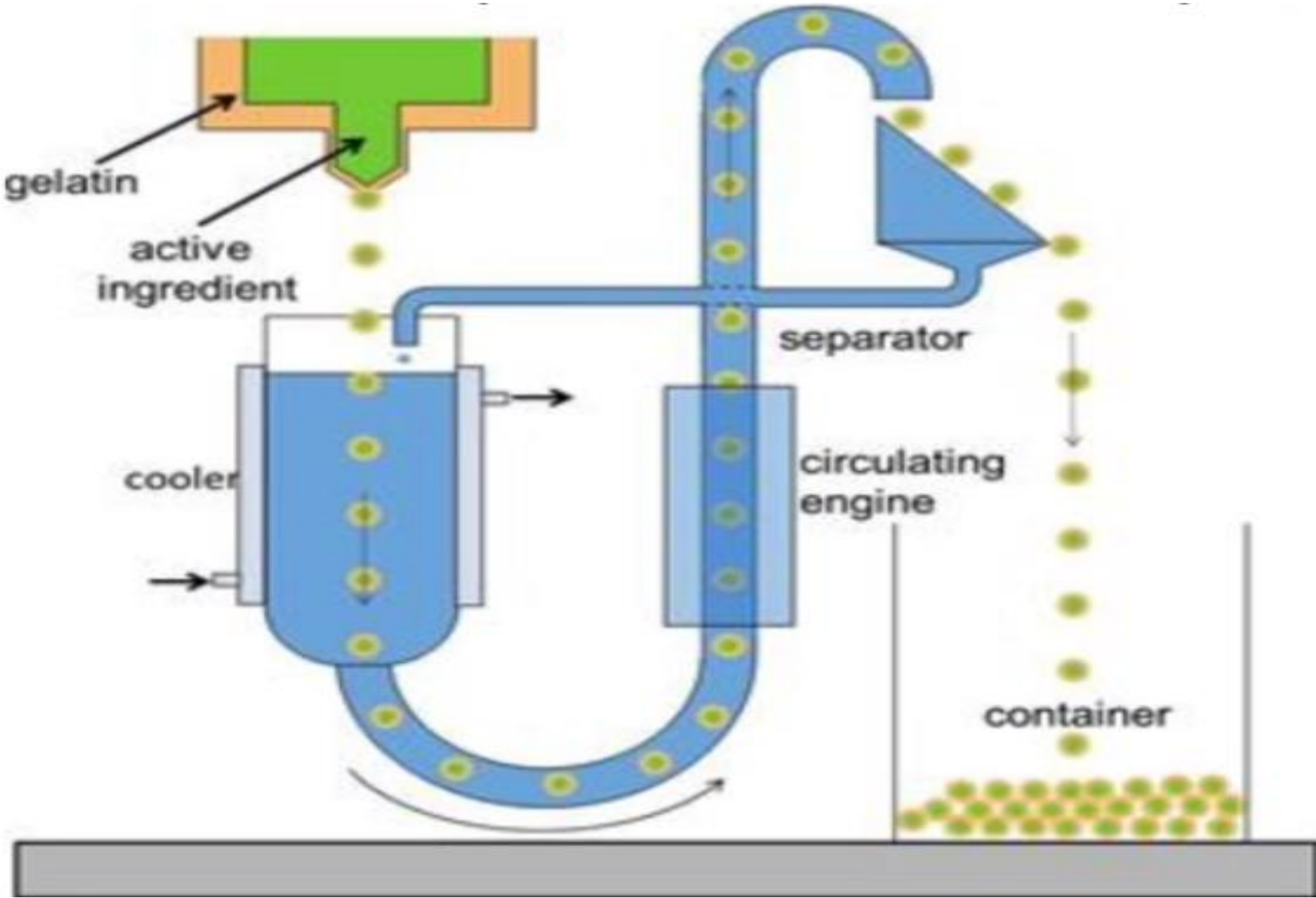

Spansules

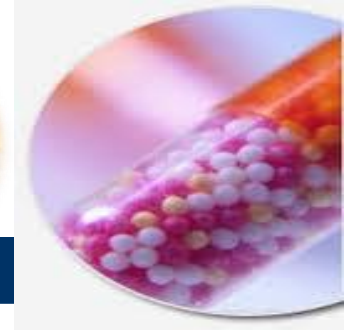

- The spansule is a HGCs containing many coated beads or pellets
- Sustained drug release capsules → are suitable for antibiotics
- Capsules containing medicines, coated with materials having slow dissolving rates so that the medicine is delivered at a time after the capsule is taken.
- In general, a sustained release dosage form is consisting of two parts:
 1. An immediate release portion.
 2. A sustained release portion which gradually release medicament

Spansules



❑ Formulation of Spansules:

- A. The medication is pan coated onto the surface of sugar starch beads using non aqueous solution of the drug.
- B. ~ 1/3 of these drug-coated beads is intended to provide the initial release of medication, and these receive no further treatment.
- C. The remainder (2/3 of the beads) are then pan coated with polymers having pH- sensitive solubility.

Advantage: Administration is more convenient, since a single dose provides all-day or all-night medication.

➤ **Fefol capsules**

Enteric coated capsules:

- They are capsules that are coated to resist the drug dissolution in gastric fluids but release their contents in the intestine.
- **This delayed release medication may be desired if:**
 - A. The drug is inactivated in the gastric fluids (as erythromycin).
 - B. The drug is irritating to the gastric mucosa (as NSAIDs).
 - C. A high local concentration of the drug is desirable in the intestine, as in the case of anthelminitics.
 - D. A delayed, controlled or sustained drug release is needed→. Higher bioavailability such as Theophylline and barbiturates.
 - E. Drug ***interfered with food digestion*** such as tannins and salts of heavy metals.

1-Enteric-coated capsules using formaldehyde

- In early time of coating technology, the main technique being used was to dip the sealed capsules into formaldehyde solutions
- **Test 1:** In test tube containing SGF, maintained at 37 C → we placed SGCs for 5 hours.
- **Test 2:** Capsules of test **1** is then washed and transferred to another test tubes containing Pancreatic simulated solution at 37 C for 2 hour
- **Enteric coated capsules should be**
 - Resist bursting (may be swell) in gastric secretions for at least 5 hrs.
 - Soluble or disintegrate in pancreatic or intestinal secretions within 2 hrs.

Enteric coated capsules:

2-Enteric-coated capsules using Synthetic polymers

- Now enteric coating usually prepared from materials that have acidic group such as Ammoniated shellac (insoluble at low pH but soluble at $\text{pH} > 5.7$)
- CAP Coat are dissolved *in vivo* by Ionization;

3-Enteric-coated capsules using other materials

- Ethylcellulose
- It dissolved *in vivo* by Hydrolysis and or Emulsification

NB. Community pharmacist may prepare Enteric coated tablets by dipping them from 4-5 times in 10% solution of cellulose acid phthalate

Capsules (Cont.):

Evaluation of commercial capsules:

1- content uniformity:

- Applied for both HGCs and SGCs
- Similar to that of tablets, 30 capsules are selected and 10 of these are assayed individually.
- The batch complies if:→ At least 9 of 10 contain 85 – 115 % of drug and none (10) contain below 75– 125% of drug.
- The batch fails → if more than three capsules are outside the limit (85-115 %) or if any one is outside 75%-125%.
- If 2 or 3 of them fall outside of 85 – 115% limits, repeat test on the remaining 20 capsules that are individually assayed → and the requirements are met if no few than 27 contain 85 – 115 % of drug and none contain less than 75 – 125 % of drug.

Capsules (Cont.):

2- Weight Uniformity :

- This test applies to all types of capsules and it is to be done on 20 capsules (randomly selected).

Method:

1. Weigh an intact capsule.
2. Open the capsule without losing any part of the shell and remove the contents as completely as possible.
3. Weigh the shell.
4. The weight of the contents is the difference between the weighing.
5. Repeat the procedure with a further 19 capsules selected at random.

Capsules (Cont.):

Limit:

- Not more than two of the individual weights deviate from the average weight by more than the percentage deviation shown in the table below, and none deviates by more than twice that percentage.

Average Weight of Capsule Content	Percentage Deviation
Less than 300 mg	10
300 mg or more	7.5

Capsules (Cont.):

3- Disintegration Time:

- The disintegration test determines whether tablets or capsules disintegrate within a prescribed time when placed in a liquid medium under the prescribed experimental conditions.



Capsules (Cont.):

Method:

According to the B.P. and applies to hard and soft capsules.

- 1 Introduce one capsule into each tube and suspend the apparatus in a beaker containing 600 ml water at 37 °C.
 - If hard capsules float on the surface of the water, the discs may be added.
- 2 Operate the apparatus for 30 minutes; remove the assembly from the liquid.
- 3 The capsules pass the test if
 - No residue remains on the screen of the apparatus or,
 - If a residue remains, it consists of fragments of shell or,
 - Is a soft mass with no palpable core.
 - If the disc is used, any residue remaining on its lower surface should only consist of fragments of shell.

Capsules (Cont.):

4- Dissolution:

- The dissolution test is carried out using the dissolution apparatus official in both the U.S.P. and N.F.
- The capsule is placed in a basket formed from 40-mesh stainless steel fabric.
- A stirrer shaft is attached to the basket, and the basket is immersed in the dissolution medium and caused to rotate at a specified speed.
- The dissolution medium is held in a covered 1000 ml glass vessel and maintained at $37^{\circ}\text{C} \pm 0.5^{\circ}\text{C}$ by means of a suitable constant-temperature water bath.
- The stirrer speed and type of dissolution medium are specified in the individual monograph.

Capsules (Cont.):

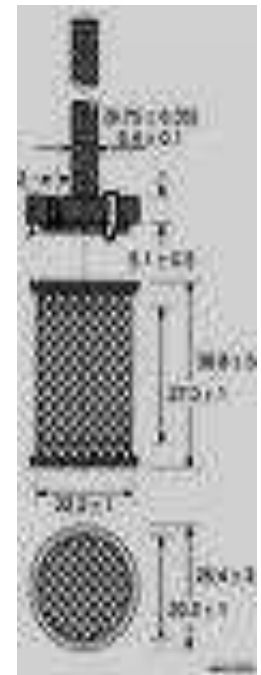
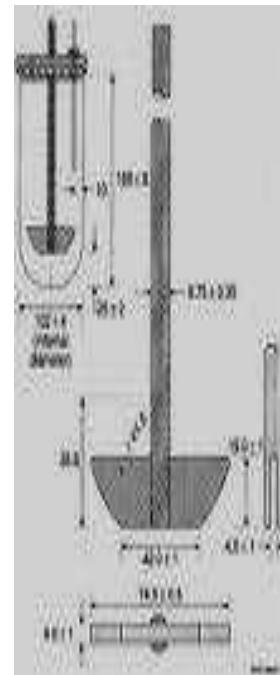

HARD GELATIN CAPSULE

- 1) Two pieces (large body & short cap)**
- 2) Cylindrical shape.**
- 3) Powder drug or pellets coated with drug are encapsulated.**
- 4) Gelatin in Hard form is used.**
- 5) Capsules sealed after filled to ensure that medicaments not come out of capsule due to rough handling.**
- 6) 8 different type of sizes are available**

SOFT GELATIN CAPSULE

- 1) One piece & hermetically sealed.**
- 2) Available in round , oval & tube like shapes.**
- 3) Liquid & Semi liquid fill & unstable substances are encapsulated.**
- 4) Molten gelatin are used.**
- 5) Filling & sealing of soft gelatin capsules are done in a combined operation on machine.**
- 6) No specific sizes are available**